

NUCLEAR STRUCTURE '98 Nuclear Transport: Run by Ran?

Mary Dasso and Robert T. Pu

Laboratory of Molecular Embryology, National Institute of Child Health and Human Development, National Institutes of Health, Bethesda

A distinguishing feature of eukaryotic cells is the compartmentalization of their DNA within the nucleus. The sequestration of the genetic material away from the translational machinery and cytosolic proteins has at least two obvious but important implications: First, there must be a mechanism whereby the separate identities of the nucleus and cytosol are established and maintained within each cell cycle. The existence of such a mechanism was confirmed by the finding that many karyophilic proteins have nuclear localization sequences (NLS) (Gorlich and Mattaj 1996). NLS-bearing proteins enter the nucleus through a process that can be subdivided into at least two steps: a receptor-mediated, energy-independent docking on the cytosolic face of the nuclear pore complex (NPC) and an energy-dependent translocation of the docked NLS-bearing protein (substrate) into the nucleus (Gorlich and Mattaj 1996). Second, it is clear that differential access of proteins to the nucleus may be used as an important regulatory step for signal-transduction pathways, cell-cycle control, or developmental processes. It frequently has been found that import of proteins into the nucleus is modulated at the level of substrate accessibility (e.g., by posttranslational modification or dissociation from other proteins [Nigg 1997]). It is likely that the transport machinery itself is also regulated, although this has not yet been as clearly demonstrated.

Recent advances in this field also have shown that the nuclear transport machinery is highly conserved. This conservation suggests that findings about nuclear transport mechanisms and their regulation in different experimental systems may be broadly applicable to diverse organisms, including humans. In this review, we will briefly discuss soluble proteins involved in nuclear transport, with a particular focus on Ran, a small GTPase that is essential for transport in all eukaryotic organisms. Because of the brevity of this review, our discussion of transport mechanisms will not be as comprehensive as

that presented within some excellent recent reviews (Gorlich and Mattaj 1996; Nigg 1997; Weis 1998); rather, we hope to emphasize some of the emerging paradigms for the regulation of nuclear transport in higher eukaryotes.

Ran, Ran-Interacting Proteins, and Their Functions

Ran is a small nuclear GTPase that is very abundant and highly conserved among species from yeast to mammals (Rush et al. 1996). Both in vivo yeast genetics and in vitro cell-biology and biochemical studies suggest that Ran is required for active nuclear transport (Moore and Blobel 1993; Corbett and Silver 1997; Melchior and Gerace 1998). In permeabilized-cell nuclear import assays, the nuclear import of NLS-bearing substrates is reconstituted by incubation of the permeabilized cells with crude cytosol or purified Ran, importin α , importin β , and NTF2 (nuclear transport factor 2) proteins. These proteins are found in all eukaryotes, from yeast to humans, suggesting a strong cross-species conservation of the nuclear transport machinery and mechanism.

Like other Ras family members, Ran alternates between its GDP- and GTP-bound states. Ran's nucleotide exchange and hydrolysis are facilitated by a nucleotide-exchange factor called "RCC1" and a GTPase-activating protein called "RanGAP1," respectively. RCC1 is a chromatin-associated nuclear protein (Dasso 1995). There are two forms of RanGAP1 in vertebrates: an unmodified form and a covalent conjugate with SUMO-1, a small ubiquitin-related modifier (Saitoh et al. 1997). Both forms stimulate GTP-Ran hydrolysis, but only the SUMO-1-conjugated RanGAP1 is targeted to NPC, by its association with RanBP2 (also called "Nup358"), an NPC protein located on the cytosolic face of the pore (Saitoh et al. 1997). The association of RanGAP1 with RanBP2 appears to be required for protein import in permeabilized-cell assays (Mahajan et al. 1997). Ran is also regulated by RanBP1, a guanine nucleotide-dissociation factor, and related proteins. RanBP1 is a highly conserved cytosolic protein with both a high affinity for GTP-bound Ran and a low affinity for GDP-bound Ran. RanBP1 acts as a cofactor for RanGAP1, increasing the rate of RanGAP1-mediated GTP-Ran hydrolysis by ~10-fold (Bischoff et al. 1995). There are a number of pro-

Received June 11, 1998; accepted for publication June 16, 1998; electronically published July 17, 1998.

Address for correspondence and reprints: Dr. Mary Dasso, Laboratory of Molecular Embryology, NICHD/NIH, Building 18T, Room 106, Bethesda, MD 20892-5431. E-mail: mdasso@helix.nih.gov

© 1998 by The American Society of Human Genetics. All rights reserved.
0002-9297/98/6302-0004\$02.00

teins that possess domains with significant sequence homology with the Ran-binding domain of RanBP1. The best characterized of these proteins is RanBP2 (Seki et al. 1996). RanBP2 contains multiple docking sites for receptor-import substrate complexes (FXFG peptide repeats) and four Ran-binding domains that each, individually, act in a manner analogous to RanBP1. Furthermore, RanBP2 associates tightly with Ubc9p, a SUMO-1-conjugation enzyme, and SUMO-1-conjugated RanGAP1 (Saitoh et al. 1997). Taken together, these properties of RanBP2 have inspired considerable speculation that RanBP2 might act as a scaffold to coordinate nucleotide hydrolysis by Ran, with nuclear translocation of substrates that are docked on the cytosolic face of the pore (Melchior and Gerace 1998). Although this speculation is appealing, it has been experimentally difficult to prove, because the biochemical properties of RanBP2 make it unwieldy to manipulate.

Importin α and importin β together act as a heterodimeric receptor for the import of proteins bearing a classical NLS (Gorlich and Mattaj 1996). Importin α recognizes NLS-bearing proteins, and importin β facilitates their association with the NPC, by directly interacting with NPC proteins with FXFG peptide motifs. This interaction is responsible for the Ran-independent docking of transport complexes on the cytosolic face of the nuclear pore prior to Ran-dependent translocation. GTP-Ran binds strongly to importin β and causes it to dissociate from importin α , causing the release of the imported substrates (Koepp and Silver 1996). The transport of proteins with noncanonical NLS, the shuttling of hnRNP proteins, and the export of proteins bearing nuclear export sequences are facilitated by other proteins related to importin β (Weis 1998; Wozniak et al. 1998). One example is CAS, which mediates the transport of importin α out of the nucleus after each round of NLS protein import (Gorlich 1998). Other than importin β , the characterized members of the importin β family appear to bind directly to their transport substrates, having no need of any importin α -like adaptor (Weis 1998; Wozniak et al. 1998). Whereas binding of GTP-Ran causes some members of this family to dissociate from their transport cargo, as importin β does, others, such as CAS, associate with cargo only when they are bound to GTP-Ran (Gorlich 1998). NTF2, a 14.5-kD protein, may facilitate the Ran-dependent translocation by stabilizing the GDP-bound Ran, thereby either promoting Ran's interaction with other components of the nuclear transport machinery or serving to maintain transport directionality (Stewart et al. 1998).

A Possible Mechanism for Ran's Function in Nuclear Transport

The mechanism whereby Ran facilitates nuclear transport is still poorly understood. It is also controversial

whether nucleotide hydrolysis by Ran is the sole energy-dependent process in nuclear transport or whether other GTPases or ATPases are required (Sweet and Gerace 1996; Weis et al. 1996). However, current knowledge leads to several constraints on any proposed mechanism. The exclusive localization of RCC1 in the nucleus and of RanGAP1 in cytosol implies that Ran nucleotide exchange and hydrolysis occur in different compartments. It also predicts a steep gradient of GTP-Ran across the nuclear envelope, such that the GTP-Ran:GDP-Ran ratio is high in the nucleus and low in the cytosol. Finally, the capacity of GTP-Ran to dissociate importin α/β and NLS substrate complexes suggests that these complexes might assemble in the cytosol but would be unstable in the nucleus.

A number of models have been proposed for Ran-mediated transport. One model that recently has gained experimental support suggests that the concentration of GTP-Ran serves both to mark the compartmental identity of the nucleus and the cytosol and to establish directionality in nuclear import and export. In this model, the binding of transport receptors to their substrates is regulated in different compartments by the relative concentrations of GTP- and GDP-Ran (Gorlich and Mattaj 1996; Gorlich 1998). Import substrates and their receptors would form tight complexes in the cytosol in the absence of GTP-Ran, but the high concentration of GTP-Ran in the nucleus would cause the dissociation of these complexes. Export substrates and their receptors would be regulated inversely by GTP-Ran. Such a scheme for the transport of classical NLS-bearing proteins is diagrammed in figure 1. Recent analyses of permeabilized cells (Kose et al. 1997; Gorlich 1998; Nakielny and Dreyfuss 1998) and of microinjected cells (Richards et al. 1997) have suggested that maintenance of the gradient of GTP-Ran across the nuclear envelope is essential for transport but that GTP-Ran hydrolysis is not coupled directly to the translocation of importin β family members. Such results support this type of model for nuclear transport. It is important to note that this model is still highly speculative. Our understanding of nuclear transport is rapidly changing, and there are numerous pieces of experimental evidence that are not fully explained by any model proposed to date (e.g., our understanding of both the biophysical events involved in the translocation of substrates across the pore and the role of NTF2 remain particularly murky).

Disruption of the Ran GTPase Pathway: Analysis of *Xenopus* Egg Extracts and of Mutants in Metazoans

Manipulations of the Ran GTPase pathway have indicated that dysregulation of nuclear transport may have profound and sometimes unexpected consequences for cells. The relationship of Ran to nuclear assembly and

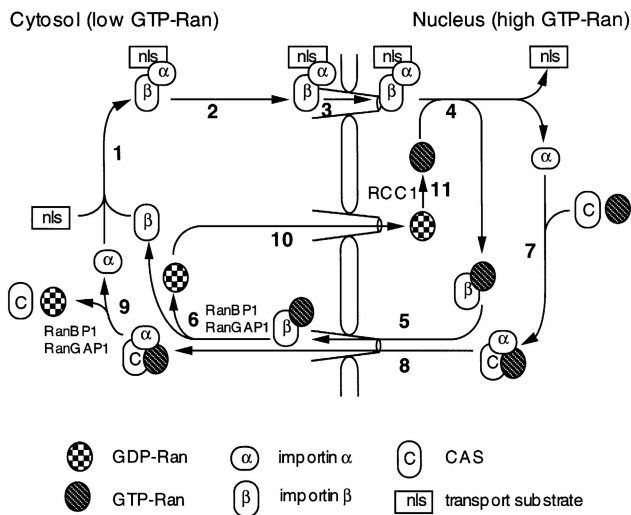

Figure 1 Transport model wherein Ran promotes NLS-mediated protein import through association and dissociation of transport complexes. The sequence of steps shown is as follows: 1, formation of a heterotrimeric complex containing the transport substrate, importin α , and importin β ; 2, docking of the transport complex on the NPC; 3, translocation of the transport complex across the nuclear pore; 4, GTP-Ran binding to importin β and dissociating the transport complex; 5, GTP-Ran and importin β shuttling back to the cytosol; 6, GTP-Ran being hydrolyzed by cytosolic RanGAP1 and RanBP1, leading to dissociation of GDP-Ran from importin β ; 7, CAS and GTP-Ran binding to importin α ; 8, CAS-importin α -GTP-Ran complex shuttling back to the cytosol; 9, GTP-Ran being hydrolyzed by cytosolic RanGAP1 and RanBP1, leading to dissociation of the CAS-importin α -Ran complex; 10, GDP-Ran shuttling into the nucleus; and 11, RCC1 promoting GDP-Ran exchange with GTP, to form GTP-Ran. This scheme is similar to that proposed by Gorlich (1998).

to the cell cycle has been studied in *Xenopus* egg extracts and in temperature-sensitive mutant-cell lines. The results of these studies have highlighted a requirement for Ran in postmitotic nuclear assembly and in maintenance of the checkpoints that prevent premature mitosis in the presence of unreplicated DNA.

Xenopus egg extracts have been used for the study of Ran in vitro. Nuclei assembled from chromatin templates in interphase *Xenopus* egg extracts are both morphologically normal and functional for DNA replication and nuclear transport (Smythe and Newport 1991). A dominant-negative Ran mutant (RanT24N) that inhibits RCC1's GEF activity causes highly abnormal nuclear assembly, blocks nuclear import, and inhibits DNA replication; this phenotype is very similar to that observed when RCC1 is depleted from egg extracts before nuclear assembly (Dasso 1995). These observations are consistent with the conclusions, from the study of other organisms, that Ran is essential for nuclear transport and function. Surprisingly, depletion of RanBP1 from interphase egg extracts results in codepletion of RCC1, sug-

gesting that complexes containing RCC1 and RanBP1 are more stable in *Xenopus* eggs than would be predicted from the analysis of purified proteins (Pu and Dasso 1997). Extracts lacking both RanBP1 and RCC1 (i.e., codepleted extracts) sustain normal nuclear assembly, DNA replication, and nuclear transport. Nuclear assembly, DNA replication, and nuclear transport are defective when codepleted extracts are supplemented with either exogenous RanBP1 or RCC1, thereby generating extracts lacking only one of the two proteins. The differential capacity of distinct mutant Ran proteins to rescue extracts lacking either RanBP1 or RCC1 suggests that the relative levels of GTP- and GDP-Ran are critical in this system and that treatments that might disrupt these ratios have drastic consequences for nuclear assembly and transport (Pu and Dasso 1997). Such findings are generally consistent with the model discussed above.

Cycling-egg extracts made from *Xenopus* egg can mimic cell-cycle transitions of the early embryo. These extracts alternate spontaneously between interphase and mitosis, with repeated rounds of nuclear-envelope breakdown, chromosome condensation, and activation of the mitotic kinase cyclin B/p34^{cdc2}. Cycling extracts respond appropriately to some cell-cycle checkpoint stimuli and will arrest their cell cycles if unreplicated DNA is present. The effects of mutant Ran proteins on the regulation of mitosis may be probed in this system. In cycling extracts without nuclei, RanT24N blocks cyclin B/p34^{cdc2} activation, indicating that Ran may regulate mitosis in a manner independent of nuclear transport (Dasso 1995). More-recent studies have revealed that the abundance of RanBP1 is regulated in mouse NIH3T3 cells (Battistoni et al. 1997), in HeLa cells, and during *Xenopus* embryo development (R. T. Pu, unpublished data). Furthermore, overexpression of RanBP1 can cause both premature entry into mitosis in the presence of unreplicated DNA in *Xenopus* egg extracts (R. T. Pu, unpublished data) and disruption of mitosis in tissue-culture cells (Battistoni et al. 1997).

Mitosis is disrupted also in tsBN2 cells, a temperature-sensitive hamster kidney-cell line with a mutant form of RCC1. At the restrictive temperature, loss of RCC1 results in nuclear transport defects and an inability to pass through the G₁/S cell-cycle transition (Seki et al. 1996). This cell-cycle defect may result directly or indirectly from decreased levels of nuclear transport, although the role of transport in the G₁/S transition in mammalian cells has not yet been well characterized. More striking, however, is the fact that tsBN2 cells also show defects in mitotic checkpoint regulation (Seki et al. 1996): tsBN2 cells that are blocked in S phase by treatment with hydroxyurea will enter mitosis prematurely at the restrictive temperature, despite incomplete DNA replication, resulting in dramatic premature chromosome condensation (PCC). This PCC is a true mitosis,

by a number of criteria: it is accompanied by full activation of the p34^{cdc2}/cyclin B kinase, nuclear-envelope breakdown, and mitotic spindle formation (Seki et al. 1996). Postmitotic nuclear assembly also is disrupted profoundly in tsBN2 cells at the restrictive temperature (Seki et al. 1996). Taken together, these observations argue that maintenance of the Ran GTPase pathway is important for the correct regulation of entry into and exit from mitosis in vertebrates. These observations also suggest the possibility that Ran may have a dual role—both regulating nuclear transport and independently interacting with other mitotic effectors.

Interestingly, it recently has been demonstrated that the Segregation Distorter (SD) gene in *Drosophila melanogaster* is a naturally occurring tandem duplication of RanGAP1, wherein one copy of RanGAP1 is intact and the second lacks C-terminal sequences, including the SUMO-1–modification site (Merrill et al. 1998). The SD system is an example of meiotic drive: When an SD/SD+ heterozygous male is crossed with an SD+/SD+ (wild-type) female, the SD chromosome is recovered among the progeny, at a frequency that greatly exceeds the expected Mendelian ratio. It has been demonstrated that this skewing of the progeny ratios results from the failure of SD+ spermatids to undergo the final chromosomal condensation and differentiation events required for the production of mature sperm. It is currently unclear how SD+ sperm are selectively prevented from differentiation under these conditions, but it is certainly attractive to speculate that there may be some link between the phenomenon and the role of Ran in cell-cycle regulation and nuclear-envelope breakdown/reassembly in other systems.

Possible Mechanisms for the Regulation of Nuclear Transport

Although the mechanism of Ran-mediated nuclear transport is still not fully understood, enough is now known to suggest possible mechanisms whereby nuclear transport may be regulated in vivo through alterations in the transport machinery. Given the large and growing family of transport receptors, differential expression of particular receptors may help control cellular processes. Currently, this sort of regulatory mechanism has been best documented for importin α subtypes. Although there is a single importin- α gene in *Saccharomyces cerevisiae*, there are at least four importin- α subtypes in mammalian cells (Nadler et al. 1997; Miyamoto et al. 1997; Nachury et al. 1998). These subtypes all appear to import NLS-bearing proteins but have different tissue distributions and varying affinities for different classes of NLS. These properties suggest that metazoans may have evolved multiple NLS receptors in order to regulate transport in a tissue-specific fashion. This idea is also

supported by the finding that pendulin, a *D. melanogaster* importin- α homologue, is not essential for viability but that its inactivation causes transformation of hematopoietic precursor cells (Kussel and Frasch 1995). Interestingly, pendulin redistributes between the nucleus and the cytosol during the cell cycle (Kussel and Frasch 1995), consistent with it promoting nuclear import in a cell cycle–specific manner. To our knowledge, neither differential receptor stability nor posttranslational regulation of receptor activity have been clearly demonstrated. However, it seems likely that such regulation will be observed as individual receptors are investigated under a greater variety of cellular conditions.

It is also possible to imagine conditions of stress in which it might be appropriate to globally inhibit nuclear transport. For instance, the export of spliced mRNAs in mammalian cells drops precipitously after heat shock. In yeast, Ran-dependent mRNA export is rapidly inhibited after heat shock, but transcripts from intronless heat-shock protein genes are still exported in a Ran-independent manner (Saavedra et al. 1997; Stutz et al. 1997). Under non-heat-shocked conditions, these mRNAs are exported in a Ran-dependent manner. Rip1p, a possible nucleoporin, is required for the export of mRNAs after heat shock but is dispensable for mRNA export under normal growth conditions (Saavedra et al. 1997; Stutz et al. 1997). Taken together, these observations have led to the proposal that there are at least two independently regulated RNA export pathways, one that is dependent on Ran and independent of Rip1p and a second that is dependent on Rip1p and independent of Ran. Under stressed conditions, heat-shock mRNAs might be shunted into the latter pathway to ensure their efficient export while the Ran-dependent pathway is nonfunctional. Interestingly, Rip1p originally was discovered as a two-hybrid interactor with HIV-1 Rev (Saavedra et al. 1997; Stutz et al. 1997), leading to the suggestion that Rev acts to direct the export of intron-containing viral mRNAs by directing them into the second Ran-independent pathway (Saavedra et al. 1997; Stutz et al. 1997). The Ran GTPase pathway also appears to be a primary target of other viruses, since the VSV-M protein also rapidly disrupts Ran-dependent export of cellular RNAs (Her et al. 1997).

Finally, we would speculate that nuclear transport could be globally regulated by control of the SUMO-1 conjugation of RanGAP1. This possibility is interesting both because many SUMO-1–conjugation substrates are not associated with the NPC (Saitoh et al. 1997) and because changes in the overall rate of SUMO-1 modification could potentially coordinate nuclear transport with other nuclear functions. Two of the SUMO-1–conjugation substrates that have been identified in vertebrates, PML and Sp100, are not associated (Sternsdorf et al. 1997; Muller et al. 1998). PML bodies are nuclear

structures of unknown function that contain the PML proto-oncoprotein and the Sp100 antigen (Doucas and Evans 1996; Hodges et al. 1998 [in this issue]). Disruption of PML bodies is associated with cellular transformation in patients with acute promyelocytic leukemia. The size and number of PML bodies appear to be regulated both in the cell cycle and in response to cellular stress (Doucas and Evans 1996). Moreover, a number of early viral gene products are targeted to PML bodies, resulting in their disruption (Doucas and Evans 1996). The conjugation of SUMO-1 to PML and Sp100 correlates with their association to PML bodies (Sternsdorf et al. 1997; Muller et al. 1998). In the future, it will be of interest to determine whether the Ran GTPase pathway and the targeting of components to PML bodies might be under coordinate control.

At present, the significance of all of these regulatory mechanisms remains to be demonstrated. Clearly, the next few years will bring us a much better understanding of the regulation of nuclear transport pathways under different cellular conditions, as well as a better awareness of the role of nuclear transport components in viral infection, human health, and disease.

Acknowledgments

We would like to thank Drs. Petr Kalab, Yoshiaki Azuma, Hisato Saitoh, and Margaret Cavenagh for insightful discussions and for critical reading of the manuscript. We apologize to the authors of relevant articles that, because of the space limitations of this review's format, have been cited only in reviews.

References

- Battistoni A, Guarguaglini G, Degrassi F, Pittoggi C, Palena A, Di Matteo G, Pisano C, et al (1997) Deregulated expression of the RanBP1 gene alters cell cycle progression in murine fibroblasts. *J Cell Sci* 110:2345–2357
- Bischoff FR, Krebber H, Smirnova E, Dong W, Ponstingl H (1995) Co-activation of Ran GTPase and inhibition of GTP dissociation by Ran-GTP binding protein RanBP1. *EMBO J* 14:705–715
- Corbett AH, Silver PA (1997) Nucleocytoplasmic transport of macromolecules. *Microbiol Mol Biol Rev* 61:193–211
- Dasso M (1995) The role of the Ran GTPase pathway in cell cycle control and interphase nuclear functions. *Prog Cell Cycle Res* 1:163–172
- Doucas V, Evans RM (1996) The PML nuclear compartment and cancer. *Biochim Biophys Acta* 1288:M25–M29
- Gorlich D (1998) Transport into and out of the cell nucleus. *EMBO J* 17:2721–2727
- Gorlich D, Mattaj IW (1996) Nucleocytoplasmic transport. *Science* 271:1513–1518
- Her LS, Lund E, Dahlberg JE (1997) Inhibition of Ran guanosine triphosphatase-dependent nuclear transport by the matrix protein of vesicular stomatitis virus. *Science* 276:1845–1848
- Hodges M, Tissot C, Howe K, Grimwade D, Freemont PS (1998) Structure, organization, and dynamics of promyelocytic leukemia nuclear bodies. *Am J Hum Genet* 63:297–304 (in this issue)
- Koepp DM, Silver PA (1996) A GTPase controlling nuclear trafficking: running the right way or walking RANdomly? *Cell* 87:1–4
- Kose S, Imamoto N, Tachibana T, Shimamoto T, Yoneda Y (1997) Ran-unassisted nuclear migration of a 97-kD component of nuclear pore-targeting complex. *J Cell Biol* 139:841–849
- Kussel P, Frasch M (1995) Yeast Srp1, a nuclear protein related to Drosophila and mouse pendulin, is required for normal migration, division, and integrity of nuclei during mitosis. *Mol Gen Genet* 248:351–363
- Mahajan R, Delphin C, Guan T, Gerace L, Melchior F (1997) A small ubiquitin-related polypeptide involved in targeting RanGAP1 to nuclear pore complex protein RanBP2. *Cell* 88:97–107
- Melchior F, Gerace L (1998) Two-way trafficking with Ran. *Trends Cell Biol* 8:175–179
- Merrill C, Bayraktaroglu L, Kusano A, Ganetzky B (1998) Evidence that Segregation Distorter is a dominant gain-of-function mutation of the nuclear transport gene RanGAP1. 39th Annual Drosophila Research Conference, Washington, DC, March 25–29
- Miyamoto Y, Imamoto N, Sekimoto T, Tachibana T, Seki T, Tada S, Enonoto T, et al (1997) Differential modes of nuclear localization signals (NLS) recognition by three distinct classes of NLS receptors. *J Biol Chem* 272:26375–26381
- Moore MS, Blobel G (1993) The GTP-binding protein Ran/TC4 is required for protein import into the nucleus. *Nature* 365:661–663
- Muller S, Matunis MJ, Dejean A (1998) Conjugation with the ubiquitin-related modifier SUMO-1 regulates the partitioning of PML within the nucleus. *EMBO J* 17:61–70
- Nachury MV, Ryder UW, Lamond AI, Weis K (1998) Cloning and characterization of hSRP1 γ , a tissue-specific nuclear transport factor. *Proc Natl Acad Sci USA* 95:582–587
- Nadler SG, Tritschler D, Haffar OK, Blake J, Bruce AG, Cleveland JS (1997) Differential expression and sequence-specific interaction of karyopherin α with nuclear localization sequences. *J Biol Chem* 272:4310–4315
- Nakielny S, Dreyfuss G (1998) Import and export of the nuclear proteins import receptor transportin by a mechanism independent of GTP hydrolysis. *Curr Biol* 8:89–95
- Nigg EA (1997) Nucleocytoplasmic transport: signals, mechanisms and regulation. *Nature* 386:779–787
- Pu RT, Dasso M (1997) The balance of RanBP1 and RCC1 is critical for nuclear assembly and nuclear transport. *Mol Biol Cell* 8:1955–1970
- Richards SA, Carey KL, Macara IG (1997) Requirement of guanosine triphosphate-bound ran for signal-mediated nuclear protein export. *Science* 276:1842–1844
- Rush MG, Drivas G, D'Eustachio P (1996) The small nuclear GTPase Ran: how much does it Run? *Bioessays* 18:103–112
- Saavedra CA, Hammell CM, Heath CV, Cole CN (1997) Yeast

- heat shock mRNAs are exported through a distinct pathway defined by Rip1p. *Genes Dev* 11:2845–2856
- Saitoh H, Pu RT, Dasso M (1997) SUMO-1: wrestling with a new ubiquitin-related modifier. *Trends Biochem Sci* 22:374–376
- Seki T, Hayashi N, Nishimoto T (1996) RCC1 in the Ran pathway. *J Biochem* 120:207–214
- Smythe C, Newport, JW (1991) Systems for the study of nuclear assembly, DNA replication, and nuclear breakdown in *Xenopus laevis* egg extracts. *Methods Cell Biol* 35:449–468
- Sternsdorf T, Jensen K, Will H (1997) Evidence for covalent modification of the nuclear dot-associated proteins PML and Sp100 by PIC1/SUMO-1. *J Cell Biol* 139:1621–1634
- Stewart M, Kent HM, McCoy AJ (1998) Structural basis for molecular recognition between nuclear transport factor 2 (NTF2) and the GDP-bound form of the Ras-family GTPase Ran. *J Mol Biol* 277:635–646
- Stutz F, Kantor J, Zhang D, McCarthy T, Neville M, Rosbash M (1997) The yeast nucleoporin Rip1p contributes to multiple export pathways with no essential role for its FG-repeat region. *Genes Dev* 11:2857–2868
- Sweet DJ, Gerace L (1996) A GTPase distinct from Ran is involved in nuclear protein import. *J Cell Biol* 133:971–983
- Weis K (1998) Importins and exportins: how to get in and out of the nucleus. *Trends Biochem Sci* 23:185–189
- Weis K, Dingwall C, Lamond AI (1996) Characterization of the nuclear protein import mechanism using Ran mutants with altered nucleotide binding specificities. *EMBO J* 15:7120–7128
- Wozniak RW, Rout MP, Aitchison JD (1998) Karyopherins and kissing cousins. *Trends Cell Biol* 8:184–188